



fire protection systems

MC GLASS FIRE

- _ a semi-structural facade system used to design fire-rated facade structures
- _ structures based on the MC GLASS FIRE system provide the EI30, EI60, EI90, EI120 fire resistance class according to EN 13501-2:2016-07
- _ fire-rated inserts in mullions and transoms: aluminium shaped sections filled with the Aestuver fire resistant cement compound supplied by Xella
- _ the space between glasses is filled with an insulating material with thermal and fire-resistant features
- _ in order to obtain a smooth external surface, the gap is filled with UV resistant silicone
- _ a wide range of colours – RAL palette (Qualicoat 1518), texture colours, Aliplast Wood Colour Effect (wood-like colours), Aliplast Loft View – colours imitating stone surfaces (Qualideco PL-0001), anodised colour (Qualanod 1808), bi-colour

fire protection systems

technical specification

system	material	depth mullion	depth transom	glazing range	mullions rigidity	transom rigidity
MCGF	aluminium	10-326 mm	10-294 mm	4-59 mm	176,7 - 4092 cm ⁴ *	215,90 - 2293 cm ⁴ *

* There is a possibility to use additional reinforcements

performance

system	thermal insulation Uf*	air permeability	windload resistance	watertightness
MCGF	Uf from 0,88 W/m ² K	Class AEI300; EN 12152	Class 2000Pa; EN 13116	Class REI800; EN 12154

* Thermal insulation is dependent on a combination of profiles and thickness of the filling

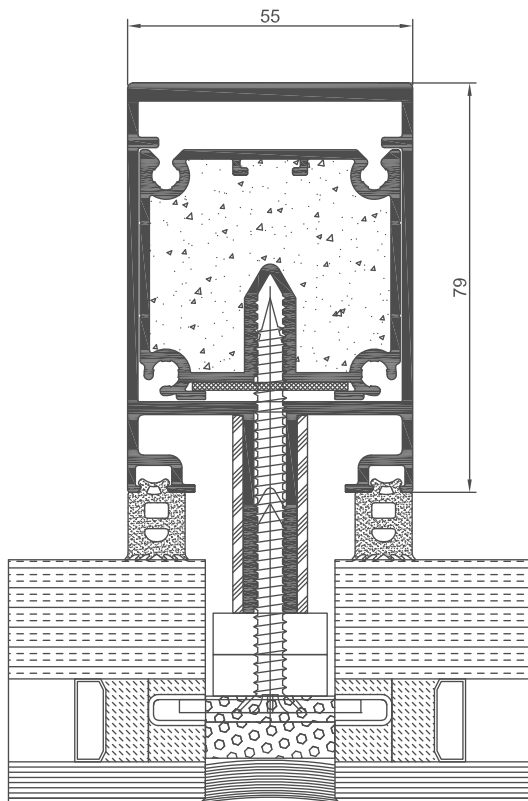

MC GLASS FIRE mullion cross section MC GLASS FIRE (MC413)

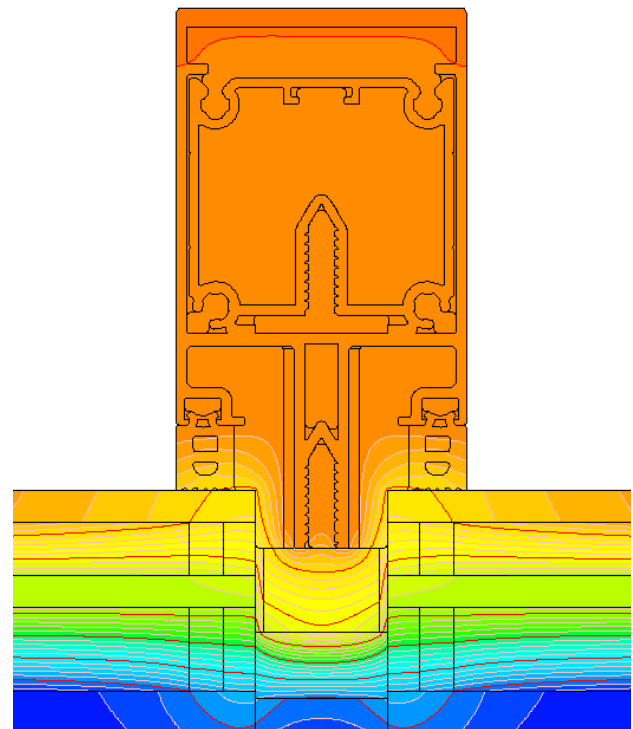

distribution of isotherms in the MC GLASS FIRE system (MC537)