**fire protection systems**
**FR 90**

- \_ thermally insulated fire protection system; application: indoor and outdoor installations
- \_ **structures designed on the basis of the FR90 system feature fire rating for walls EI30, EI60, EI 90, EI120, and fire rating for doors EI30, EI60, EI90**
- \_ installation depth: 90 mm
- \_ compatible with systems with the installation depth of 90 mm (STAR)
- \_ option of panel infill (panel thickness 60 mm): mineral wool filled panels ( $U_p = 0.57 \text{ W/m}^2\text{K}$ ), gypsum filled panels
- \_ structures: single and double doors, fixed glazing
- \_ maximum dimensions of single-sash doors: 1650 x 2870 mm
- \_ maximum dimensions of double-sash doors: 3170 x 2870 mm
- \_ single-point and multi-point door locks, electric door strikes, panic hardware
- \_ cover plate hinges, roller hinges, Inox hinges
- \_ solutions with and without thresholds
- \_ door kick plates (high plinth block)
- \_ option of air vent installation
- \_ optimised profiles (one profile type for the door frame and leaf)
- \_ quick and simple prefabrication
- \_ acoustics – acoustic testing of double doors featuring fire rating EI30 and EI60 for indoor and outdoor installations: 39 to 47 dB
- \_ a wide range of colours – RAL palette (Qualicoat 1518), texture colours, Aliplast Wood Colour Effect (wood-like colours), Aliplast Loft View – colours imitating stone surfaces (Qualideco PL-0001), anodised colour (Qualanod 1808), bi-colour

## fire protection systems

### technical specification

system	material	depth of frame	depth of leaf	glazing range	type of doors
FR90 fix	aluminium / polyamid	90 mm	—	fix 20-69 mm	—
FR90 door	aluminium / polyamid	90 mm	90 mm	door 20-69 mm	single sash door, double sash door

### performance

system	thermal insulation Uf*	air permeability	windload resistance	watertightness
FR90	Uf from 2,145 W/m²K	Class 4; EN 12207	Class C1/B2; EN 12210	Class 4A; EN 12208

\* Thermal insulation is dependent on a combination of profiles and thickness of the filling

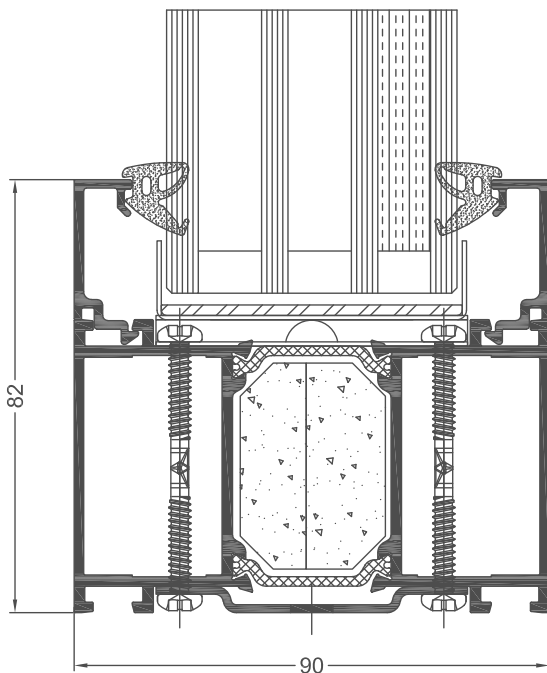

FR90 FIX cross section (FR120)

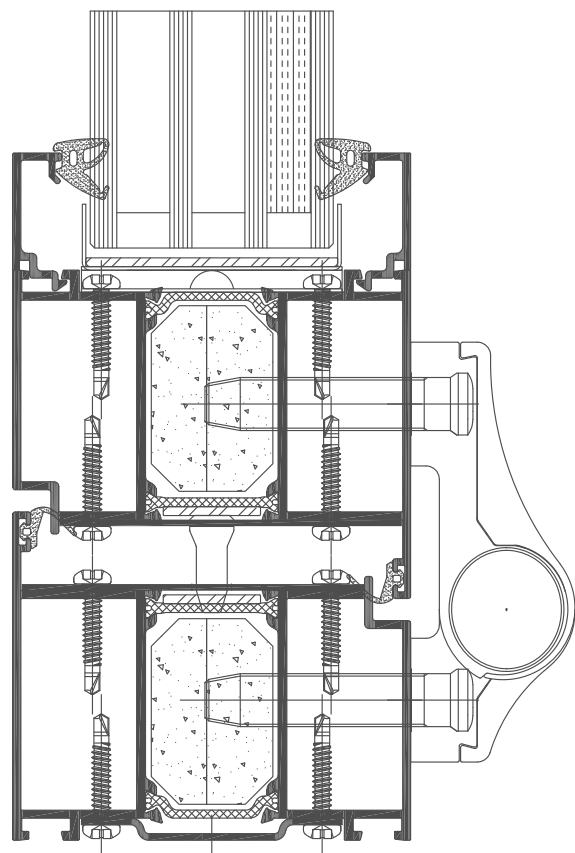

FR 90 door cross section (FR101 + FR101)